

# The Laplace Transform

These are lecture notes based on the first three sections of Chapter 6 of Boyce & DiPrima's textbook. ©2018, Michael C. Sullivan.

The Laplace transform provides a method of converting an initial value problem into an algebraic problem. We will apply it to problems of the form

$$ay'' + by' + cy = g(t), \quad y(0) = y_0 \text{ \& } y'(0) = v_0.$$

It is most helpful when the forcing term  $g(t)$  is discontinuous. However, it will take some effort to develop this method before we see how to use it.

**Definition.** The *Laplace transform* of a function  $f(t)$  is a new function  $F(s)$  given by

$$L(f) = F(s) = \int_0^{\infty} e^{-st} f(t) dt.$$

Note: the domain of  $F(s)$  is often restricted to an interval of the form  $(a, \infty)$ .

**Example 1.** Let  $f(t) = 1$ . That is  $f$  is a constant function always equal to one. We will compute its Laplace transform.

$$L(f) = F(s) = \int_0^{\infty} e^{-st} \cdot 1 \, dt = -\frac{1}{s} e^{-st} \Big|_0^{\infty} = -\frac{1}{s} \left( \left[ \lim_{t \rightarrow \infty} e^{-st} \right] - [e^0] \right).$$

Now the limit is zero if  $s > 0$ . For  $s = 0$  the limit is one and for  $s < 0$  the limit is infinity. When this happens, we restrict the domain to  $s > 0$ . Thus,

$$F(s) = \frac{1}{s}, \quad \text{for } s > 0,$$

is the Laplace transform of  $f(t) = 1$ .

**Example 2.** Let  $f(t) = \sin t$ . We will find its Laplace transform.

$$\begin{aligned} L(f) = F(s) &= \int_0^{\infty} e^{-st} \sin t \, dt = -\frac{e^{-st}}{s^2 + 1} (\cos t + s \sin t) \Big|_0^{\infty} \\ &= \frac{1}{s^2 + 1}, \quad \text{provided } s > 0. \end{aligned}$$

You should work through the details of this calculation, by hand. A little later we will use the computer, but you need to get your hands a dirty now and then to get a feel for what is going on.

**Student Exercise.** Show that  $L(\cos t) = \frac{s}{s^2 + 1}$  for  $s > 0$ .

**Example 3.** Let  $f(t) = e^{ct}$ . We compute its Laplace transform.

$$\begin{aligned} L(f) = F(s) &= \int_0^{\infty} e^{-st} e^{cs} \, dt = \int_0^{\infty} e^{(c-s)t} \, dt = \frac{e^{c-s}}{c-s} \Big|_0^{\infty} = \\ &= 0 - \frac{e^0}{c-s} = \frac{1}{s-c}, \quad \text{provided } s > c. \end{aligned}$$

We state a theorem that tells us for which functions  $f(t)$  the Laplace transform exists, then we will do more examples leading up to how the Laplace transform applies to solving differential equations. First a definition.

**Definition.** A function  $f(t)$  is said to be **dominated** by an exponential function if there exist real numbers  $a$ ,  $k$  and  $m$ , with  $k$  and  $m$  positive, such that

$$|f(t)| \leq ke^{at} \quad \text{for all } t \geq m.$$

**Example 4.** Let  $f(t) = t^4 \sin t + t^3$ . First, on a computer plot  $\pm e^t$  and  $f(t)$  over  $t \in [0, 4]$ . You might think that  $f(t)$  is not dominated by  $e^x$ . Now, redo the plot over the range  $t \in [0, 14]$ . See?

**Fact.** Every polynomial is dominated by an exponential function.

**Fact.** The function  $e^{t^2}$  is not dominated by an exponential function.

**Theorem.** (6.1.2) Suppose

- $f(t)$  is piecewise continuous on  $[0, \infty)$ , and
- $f(t)$  is dominated by an exponential function.

Then  $L(f) = F(s)$  exists for  $s > a$ .

See the textbook for the proof.

The next theorem is just a calculation we will need.

**Theorem.** For a suitable  $f(t)$ , see textbook for details, we have the following formulas.

- (a)  $L(f') = sL(f) - f(0)$ .
- (b)  $L(f'') = s^2L(f) - sf(0) - f'(0)$ .

**Proof.** (a) We use integration by parts.

$$\begin{aligned} L(f') &= \int_0^\infty e^{-st} f'(t) dt = e^{-st} f(t) \Big|_0^\infty + s \int_0^\infty e^{-st} f(t) dt \\ &= 0 - e^0 f(0) + sL(f) = sL(f) - f(0). \end{aligned}$$

(b) Repeat.

$$L(f'') = sL(f') - f'(0) = s(sL(f) - f(0)) - f'(0) = s^2L(f) - sf(0) - f'(0).$$

**Facts.** You should check that

- $L(0) = 0$ ,
- $L(cf) = cL(f)$ , where  $c$  is a constant,
- $L(f(t) + g(t)) = L(f(t)) + L(g(t))$ .

We will use these in the next examples.

**Example 5.** We will use the Laplace transform method to solve

$$y'' + y = 0, \quad y(0) = 0, \quad \& \quad y'(0) = 1.$$

We apply the Laplace transform to both sides of  $y'' + y = 0$ .

$$\begin{aligned} L(y'' + y) &= L(0). \\ L(y'') + L(y) &= 0. \\ s^2 L(y) - sy(0) - y'(0) + L(y) &= 0. \\ (s^2 + 1)L(y) - 1 &= 0. \end{aligned}$$

Next we solve for  $L(y)$ . This gives

$$L(y) = \frac{1}{s^2 + 1}.$$

Now we remember that  $L(\sin t) = \frac{1}{s^2 + 1}$ . We conclude that  $y(t) = \sin t$ . Formally, this is called finding the *inverse Laplace transform*.

$$y = L^{-1} \left( \frac{1}{s^2 + 1} \right) = \sin t.$$

**Student Exercise.** Use the Laplace transform to solve  $y'' + y = 0$ , with  $y(0) = 1$  and  $y'(0) = 0$ .

Discuss Table 6.2.1.

**Example 6.** Given  $F(s) = \frac{4}{(s-1)^3}$ , find  $f(t) = L^{-1}(F)$ .

*Solution.* By Table 6.2.1, item #11,

$$L(t^2 e^t) = \frac{2}{(s-1)^3}.$$

Therefore,

$$L^{-1}(F) = 2t^2 e^t.$$

**Example 7.** Given  $F(s) = \frac{2s-3}{s^2-4}$ , find  $f(t) = L^{-1}(F)$ .

*Solution.* We don't see anything that looks like this in Table 6.2.1. So, we give up. NOT! We use some algebra, specifically *partial fractions decomposition*.

$$\frac{2s-3}{s^2-4} = \frac{2s-3}{(s-2)(s+2)} = \frac{A}{s-2} + \frac{B}{s+2}.$$

We can solve for  $A$  and  $B$  by cross multiplying and getting two equations in two unknowns, which can be solved for  $A$  and  $B$ .

$$2s-3 = A(s+2) + B(s-2) = (A+B)s + (2A-2B).$$

Thus,  $A+B = 2$  and  $A-B = -3/2$ . We get,  $A = 1/4$  and  $B = 7/4$ .

Now then,

$$\begin{aligned} L^{-1}\left(\frac{2s-3}{s^2-4}\right) &= L^{-1}\left(\frac{1/4}{s-2} + \frac{7/4}{s+2}\right) = \\ &= (1/4)L^{-1}\left(\frac{1}{s-2}\right) + (7/4)L^{-1}\left(\frac{1}{s+2}\right). \end{aligned}$$

Now we can use Table 6.2.1. or Example 3 above to get

$$L^{-1}(F(s)) = \frac{1}{4}e^{2t} + \frac{7}{4}e^{-2t}.$$

But, today is your lucky day! Because, most Computer Algebra Systems have a command for this! Below I did the last two examples using Maple. First I loaded a package called `inttrans`, short for integral transforms. One of the commands is `invlaplace`. The format is `invlaplace(F(s), s, t)`.

```
> with(inttrans);
[adddtable, fourier, fouriercos, fouriersin, hankel, hilbert, invfourier, invhilbert,
 invlaplace, irvmellin, laplace, mellin, savetable]

> invlaplace( 4/(s-1)^3,s,t);
2 t^2 e^t

> invlaplace( (2*s-3)/(s^2-4),s,t);
1/4 e^(2 t) + 7/4 e^(-2 t)
```

**Example 8.** Use the method of Laplace transforms to solve

$$y'' + 3y' + 2y = 0, \quad y(0) = 1, \quad y'(0) = 0.$$

*Solution.* Apply the Laplace transform to both sides of the differential equation.

$$s^2 L(y) - sy(0) - y'(0) + 3(sL(y) - y(0)) + 2L(y) = L(0).$$

Simplify.

$$(s^2 + 3s + 2)L(y) - s - 3 = 0.$$

Solve for  $L(y)$ .

$$L(y) = \frac{s + 3}{s^2 + 3s + 2}.$$

Apply  $L^{-1}$  to get  $y(t)$ .

$$y = L^{-1} \left( \frac{s + 3}{s^2 + 3s + 2} \right) = L^{-1} \left( \frac{2}{s + 1} - \frac{1}{s + 2} \right) = 2e^{-t} - e^{-2t}.$$

Note: The example we just did and Example 5 above can be done far more easily using methods of Chapter 3. We are using these example here as toy problems to illustrate the new Laplace transform method. Its real utility will be for problems with discontinuous forcing functions. Toward this end we now define the *Heaviside function*. It is also called the *unit step function*.

Let

$$u_c(t) = \begin{cases} 0 & \text{for } t \leq c, \\ 1 & \text{for } t > c. \end{cases}$$

Study its graph below. Note that the vertical segment is not really part of the graph. It is an artifact of the graphing method.

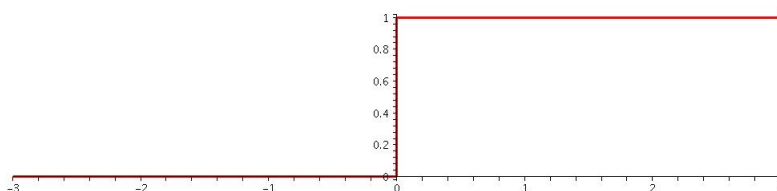

Think of it as a switch. We use it to build a wide variety of discontinuous functions or functions with “kinks” in them.

**Example 9.** Let  $f(t) = \begin{cases} 0 & \text{for } t \leq 0, \\ 2 & \text{for } 0 < t \leq 3, \\ 1 & \text{for } 3 < t. \end{cases}$

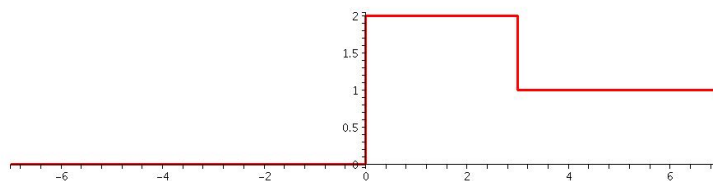

Then  $f(t) = 2u_0(t) - u_3(t)$ .

**Example 10.** Let  $g(t) = \begin{cases} 0 & \text{for } t \leq 0 \\ \sin t & \text{for } 0 < t \leq \pi \\ 0 & \text{for } \pi < t \end{cases}$

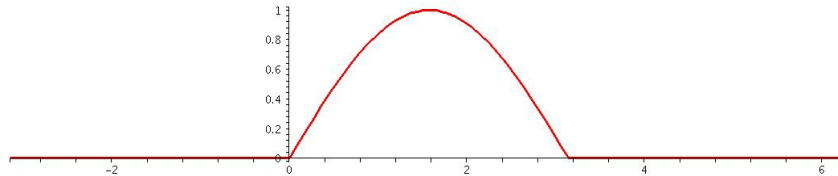

Then  $g(t) = \sin t(u_0(t) - u_\pi(t))$ .

**Example 11.** The graph of  $y = h(t)$  is below. Write a formula for  $h(t)$  in terms of Heaviside functions.

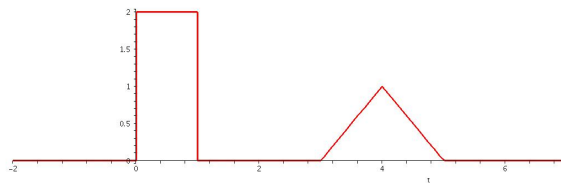

*Solution.*  $h(t) = 2(u_0(t) - u_1(t)) + (t - 3)(u_3(t) - u_4(t)) + (-t + 5)(u_4(t) - u_5(t))$ .

Here are the computer commands I used in creating the last four graphs.

- `plot(Heaviside(t),t=-3..3,thickness=2);`
- `plot(2*Heaviside(t) - Heaviside(t-3),t=-7..7,thickness=2);`
- `plot(sin(t)*(Heaviside(t)-Heaviside(t-Pi)),t=-Pi..2*Pi,thickness=2);`
- `plot(2*(Heaviside(t) - Heaviside(t-1)) + (t-3)*(Heaviside(t-3)-Heaviside(t-4)) + (-t+5)*(Heaviside(t-4)-Heaviside(t-5)),t=-2..7,thickness=2);`

Note: If you add the option `discont=true` then the vertical lines will be suppressed.

**Fact.** (Table 6.2.1 item #12.)  $L(u_c(t)) = \frac{1}{s}e^{-cs}$ , for  $s > 0$ .

*Proof.*

$$\begin{aligned} \int_0^{\infty} e^{-st} u_c(t) dt &= \int_c^{\infty} e^{-st} df = -\frac{1}{s} e^{-st} \Big|_c^{\infty} = \\ &= -\frac{1}{s} \left( \lim_{t \rightarrow \infty} e^{-st} - e^{-cs} \right) = -\frac{1}{s} (0 - e^{-cs}) = e^{-cs}, \end{aligned}$$

provided  $s > 0$ .

**Fact.** (Table 6.2.1 item #13.) Let  $f(t)$  be given and suppose  $F(s) = L(f)$ . Then

$$L(u_c(t)f(t - c)) = e^{-cs} F(s).$$

*Proof.*

$$\int_0^{\infty} e^{-st} u_c(t) f(t - c) dt = \int_c^{\infty} e^{-st} f(t - c) dt = (*).$$

Substitute  $r = t - c$ . Then  $dr = dt$  and  $t = r + c$ . Now

$$(*) = \int_0^{\infty} e^{-s(r+c)} f(r) dr = e^{-cs} \int_0^{\infty} e^{-sr} f(r) dr = e^{-cs} F(s).$$

**Fact.** (Table 6.2.1 item #14.) Let  $f(t)$  be given and suppose  $F(s) = L(f)$ . Then

$$L(e^{ct} f(t)) = F(s - c).$$

*Proof.*

$$L(e^{ct} f(t)) = \int_0^{\infty} e^{-st} e^{ct} f(t) dt = \int_0^{\infty} e^{(c-s)t} f(t) dt = F(s - c).$$

Now we shall find the Laplace transforms for the functions defined in Examples 9, 10 and 11.

$$L(f(t)) = L(2u_0(t) - u_3(t)) = 2L(u_0(t)) - L(u_3(t)) = \frac{2}{s} - \frac{e^{-3s}}{s}, \text{ for } s > 0.$$

$$\begin{aligned} L(g(t)) &= L(\sin t(u_0(t) - u_\pi(t))) = L(u_0(t) \sin t) - L(u_\pi(t) \sin(t + \pi - \pi)) = \\ &= L(\sin t) - e^{-\pi s} L(\sin(t + \pi)) = L(\sin t) + e^{-\pi s} L(\sin t) = \frac{1 + e^{-\pi s}}{1 + s^2}, \end{aligned}$$

for  $s > 0$ .

For Example 11 we will need to use that  $L(t) = 1/s^2$  for  $s > 0$ . You can compute this yourself or use Table 6.2.1 #3.

$$\begin{aligned} L(h(t)) &= L(2(u_0(t) - u_1(t)) + (t - 3)(u_3(t) - u_4(t)) + (-t + 5)(u_4(t) - u_5(t))) \\ &= 2/s - 2e^{-s}/s + L(u_3(t)(t - 3)) - L(u_4(t)(t + 1 - 4)) - L(u_4(t)(t - 1 - 4)) + L(u_5(t)(t - 5)) \\ &= 2(1 - e^{-s})/s + e^{-3s}L(t) + e^{-5s}L(t) - L(u_4(t)(t + 1 - 4 + t - 1 - 4)) \\ &= 2(1 - e^{-s})/s + (e^{-3s} + e^{-5s})/s^2 - L(u_4(t)(2t - 8)) \\ &= 2(1 - e^{-s})/s + (e^{-3s} + e^{-5s})/s^2 - 2L(u_4(t)(t - 4)) \\ &= (2 - 2e^{-s})/s + (e^{-3s} + e^{-5s})/s^2 - 2e^{-4s}L(t) \\ &= 2(1 - e^{-s})/s + (e^{-3s} - 2e^{-4s} + e^{-5s})/s^2, \end{aligned}$$

for  $s > 0$ .

Now we put the pieces together to solve some nontrivial diff eqs.

**Example 12.** Solve  $y'' + y = f(t) = u_{10\pi}(t) - u_{20\pi}(t)$ , with initial condition  $y(0) = y'(0) = 0$ . The graph of  $f(t)$  is below.

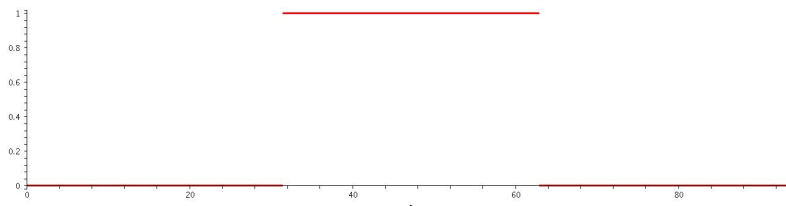

Imagine that this is a mass-string system and that an external magnet exerting a downward force of 1 is turned on at  $t = 10\pi$  and off at  $t = 20\pi$ .

*Solution.* We apply the Laplace transform and solve for  $L(y)$ .

$$L(y'' + y) = L(f)$$

$$s^2 L(y) - sy(0) - y'(0) + L(y) = \frac{e^{-10\pi} - e^{-20\pi}}{s}$$

$$L(y) = \frac{e^{-10\pi} - e^{-20\pi}}{s(s^2 + 1)}$$

Now we apply the inverse Laplace Transform.

$$y = L^{-1}(L(y)) = L^{-1}\left(\frac{e^{-10\pi}}{s(s^2 + 1)}\right) - L^{-1}\left(\frac{e^{-20\pi}}{s(s^2 + 1)}\right).$$

Let  $G(s) = \frac{1}{s(s^2+1)}$  and let  $g(t) = L^{-1}(G)$ . Then by #13

$$L^{-1}\left(\frac{e^{-10\pi}}{s(s^2 + 1)}\right) = u_{10\pi}(t)g(t - 10\pi).$$

We can find  $g(t)$  as follows.

$$g(t) = L^{-1}\left(\frac{1}{s(s^2 + 1)}\right) = L^{-1}\left(\frac{1}{s} - \frac{s}{s^2 + 1}\right) = 1 - \cos t.$$

Of course  $\cos(t - 10\pi) = \cos t$ . Thus,

$$L^{-1} \left( \frac{e^{-10\pi}}{s(s^2 + 1)} \right) = u_{10\pi}(t)(1 - \cos t)$$

Similarly,

$$L^{-1} \left( \frac{e^{-20\pi}}{s(s^2 + 1)} \right) = u_{20\pi}(t)(1 - \cos t)$$

Putting it all together we have

$$y(t) = (1 - \cos t)(u_{10\pi}(t) - u_{20\pi}(t)).$$

Below is a graph of  $y(t)$ .

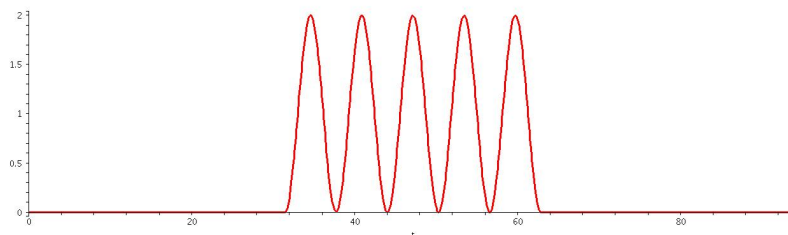

**Student Exercise.** Now, suppose we modify the problem so that the external force  $f(t)$  is turned off at  $t = 19\pi$  instead of  $20\pi$ . Show that the result is the graph below.

Write a paragraph explaining what happened.

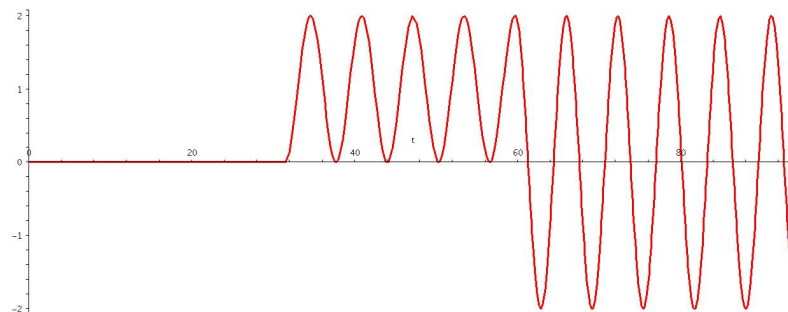

Experiment with different starting and cutoff times. See what happens.

**Example 13.** Solve  $y'' + 3y' + 2y = f(t)$  with  $y(0) = y'(0) = 0$ , where  $f(t)$  is given by the graph below.

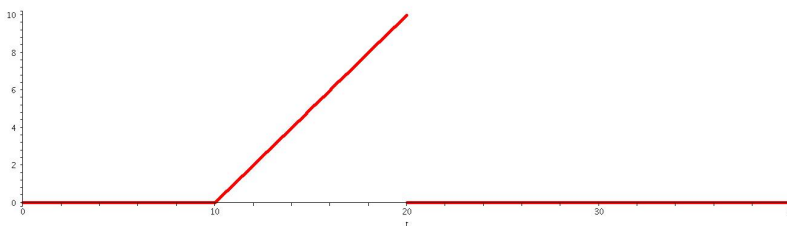

*Solution.* We write  $f(t)$  using Heaviside functions.

$$f(t) = (t - 10)(u_{10}(t) - u_{20}(t)).$$

Next we apply the Laplace Transform.

$$L(y'' + 3y' + 3y) = (s^2 + 3s + 2)L(y),$$

$$L((t - 10)u_{10}(t)) = e^{-10s}L(t - 10 + 10) = e^{-10s}\frac{1}{s^2},$$

and

$$L((t - 10)u_{20}(t)) = e^{-20s}L(t - 10 + 20) = e^{-20s}\left(\frac{1}{s^2} + \frac{10}{s}\right).$$

Thus,

$$L(f) = \frac{e^{-10s}}{s^2} - e^{-20s}\left(\frac{1}{s^2} + \frac{10}{s}\right).$$

Therefore,

$$L(y) = \frac{\frac{e^{-10s}}{s^2} - e^{-20s}\left(\frac{1}{s^2} + \frac{10}{s}\right)}{s^2 + 3s + 2}.$$

Next we need to solve for  $y(t)$  by computing the inverse Laplace transform.

$$y = L^{-1} \left( \frac{e^{-10s}}{s^2(s+2)(s+1)} - \frac{e^{-20s}}{s^2(s+2)(s+1)} - \frac{10e^{-20s}}{s(s+2)(s+1)} \right).$$

We will need to use these partial fraction expansions; you can check them.

$$\frac{1}{s^2(s+2)(s+1)} = \frac{1/2}{s^2} - \frac{3/4}{s} - \frac{1/4}{s+2} + \frac{1}{s+1},$$

and

$$\frac{1}{s(s+2)(s+1)} = \frac{1/2}{s} + \frac{1/2}{s+2} - \frac{1}{s+1}.$$

Now we have

$$\begin{aligned} y(t) = & L^{-1} \left( \frac{\frac{1}{2}e^{-10s}}{s^2} - \frac{\frac{3}{4}e^{-10s}}{s} - \frac{\frac{1}{4}e^{-10s}}{s+2} + \frac{e^{-10s}}{s+1} \right) \\ & - L^{-1} \left( \frac{\frac{1}{2}e^{-20s}}{s^2} - \frac{\frac{3}{4}e^{-20s}}{s} - \frac{\frac{1}{4}e^{-20s}}{s+2} + \frac{e^{-20s}}{s+1} \right) \\ & - L^{-1} \left( \frac{5e^{-20s}}{s} + \frac{5e^{-20s}}{s+2} - \frac{10e^{-20s}}{s+1} \right) \end{aligned}$$

We continue on the next page.

After computing each of the eleven inverse Laplace transforms we get

$$y(t) = \frac{1}{2}u_{10}(t)(t - 10) - \frac{3}{4}u_{10}(t) - \frac{1}{4}u_{10}(t)e^{-2t+20} + u_{10}(t)e^{-t+10}$$

$$-\frac{1}{2}u_{20}(t)(t - 20) + \frac{3}{4}u_{20}(t) + \frac{1}{4}u_{20}(t)e^{-2t+40} - u_{20}(t)e^{-t+20}$$

$$-5u_{20}(t) - 5u_{20}(t)e^{-2t+40} + 10u_{20}(t)e^{-t+20}$$

Finally, we simplify in two steps to get

$$y(t) = \left( \frac{t - 10}{2} - \frac{3}{4} - \frac{e^{-2t+20}}{4} + e^{-t+10} \right) u_{10}(t) +$$

$$\left( -\frac{1}{2}(t - 20) + \frac{3}{4} + \frac{1}{4}e^{-2t+40} - e^{-t+20} - 5 - 5e^{-2t+40} + 10e^{-t+20} \right) u_{20}(t)$$

$$= \frac{1}{4} (2t - 23 - e^{-2t+20} + 4e^{-t+10}) u_{10}(t) +$$

$$\frac{1}{4} (23 - 2t - 19e^{-2t+40} + 36e^{-t+20}) u_{20}(t).$$

Here then is a graph of the solution.

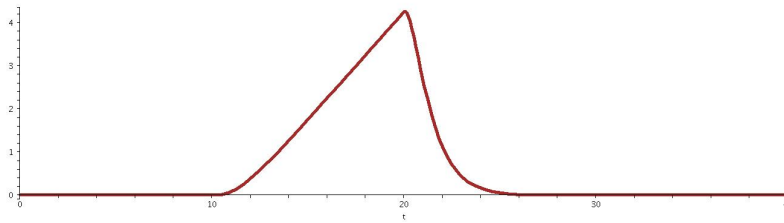

**Example 14.** We consider the RLC circuit shown below.

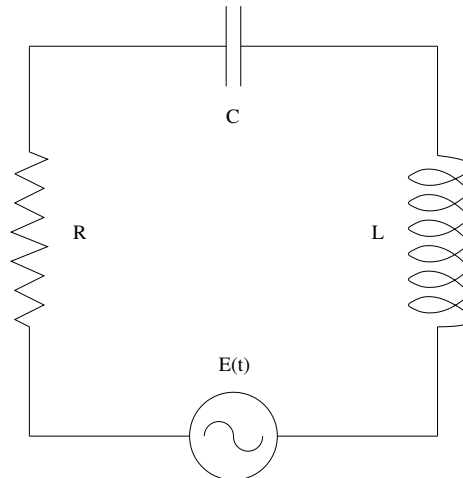

We will use  $L = 10$ ,  $R = 1$  and  $C = 0.2$ . The external voltage  $E(t)$  is given by the graph below, where the hump is  $\sin t$ . We will assume  $Q(0) = Q'(0) = 0$ . We will solve for  $Q(t)$  and plot the result. We will let the computer to most of the grunt work this time.

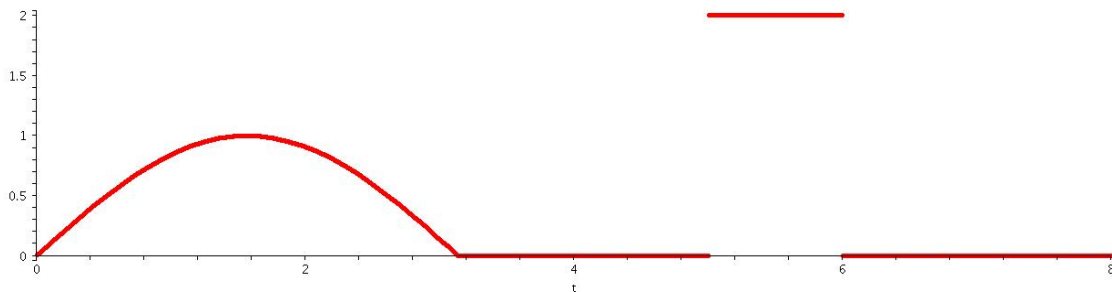

First,

$$E(t) = \sin(t)(u_0(t) - u_\pi(t)) + 2(u_5(t) - u_6(t)).$$

Then

$$Q(t) = L^{-1} \left( \frac{L(E(t))}{Ls^2 + Rs + \frac{1}{C}} \right).$$

With Maple this becomes

```
> E := t -> sin(t)*(Heaviside(t)-Heaviside(t-Pi))+2*(Heaviside(t-5)-Heaviside(t-6));  
> L:=10; R:=1; C:=0.2;  
> Q := t -> invlaplace(laplace(E(t),t,s)/(L*s^2+R*s+1/C),s,t);  
> plot(Q(t),t=0..100,thickness=3,color=blue);
```

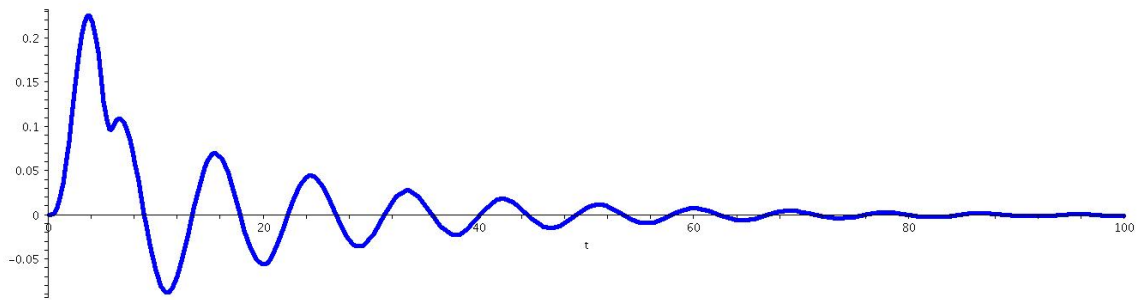

We now study periodic forcing functions.

**Theorem.** (Exercise #28 in 6.3.) Let  $f(t)$  be periodic with period  $T > 0$ . (That is  $f(t + T) = f(t)$ .) Then

$$L(f(t)) = \frac{\int_0^T e^{-st} f(t) dt}{1 - e^{-sT}}.$$

*Proof.*

$$L(f) = \int_0^{\infty} e^{-st} f(t) dt = \sum_{n=0}^{\infty} \int_{nT}^{(n+1)T} e^{-st} f(t) dt =$$

$$\sum_{n=0}^{\infty} \int_0^T e^{-s(t+nT)} f(t+nT) dt = \left( \sum_{n=0}^{\infty} e^{-snT} \right) \int_0^T e^{-st} f(t) dt = (*).$$

But,

$$\sum_{n=0}^{\infty} e^{-snT} = \sum_{n=0}^{\infty} (e^{-sT})^n = \frac{1}{1 - e^{-sT}},$$

since it is a geometric series and for  $s > 0$  we have  $e^{-sT} < 1$ . Thus,

$$(*) = \frac{\int_0^T e^{-st} f(t) dt}{1 - e^{-sT}},$$

as claimed.

**Example 15.** Solve  $y'' + y = g(t)$ , with  $y(0) = y'(0) = 0$  where  $g(t)$  is the **square wave** shown below. Plot the solution.

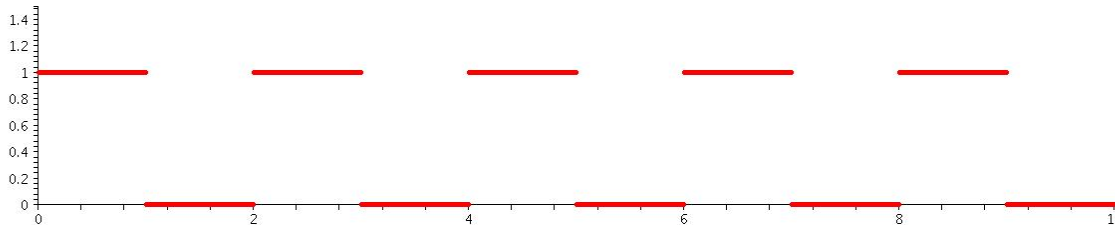

*Solution.* Apply the Laplace transform to get

$$s^2 L(y) + L(y) = L(g).$$

Thus,

$$L(y) = \frac{L(g)}{s^2 + 1}.$$

By the previous theorem

$$L(g) = \frac{\int_0^2 e^{-st} g(t) dt}{1 - e^{-2s}} = \frac{\int_0^1 e^{-st} dt}{1 - e^{-2s}} = \frac{-\frac{1}{s}e^{-s} + \frac{1}{s}}{1 - e^{-2s}} = \frac{1}{s(1 + e^{-s})}.$$

Therefore,

$$y = L^{-1} \left( \frac{1}{s(s^2 + 1)} \cdot \frac{1}{1 + e^{-s}} \right).$$

Let  $F(s) = \frac{1}{s(s^2+1)}$  and let  $f(t) = L^{-1}(F(s))$ . Thus,

$$f(t) = L^{-1} \left( \frac{1}{s(s^2 + 1)} \right) = L^{-1} \left( \frac{1}{s} - \frac{s}{s^2 + 1} \right) = 1 - \cos t.$$

Since  $s > 0$  we have  $e^{-s} < 1$ . Then the formula for a convergent geometric series gives us

$$\frac{1}{1 - (-e^{-s})} = 1 - e^{-s} + e^{-2s} - e^{-3s} + \dots = \sum_{n=0}^{\infty} (-1)^n e^{-ns}.$$

Table 6.2.1 item #13 says

$$L^{-1}(e^{-ns}F(s)) = u_n(t)f(t - n).$$

Therefore,

$$y(t) = \sum_{n=0}^{\infty} (-1)^n u_n(t)(1 - \cos(t - n)).$$

Below is a plot of  $y(t)$  for  $0 \leq t \leq 40$ .

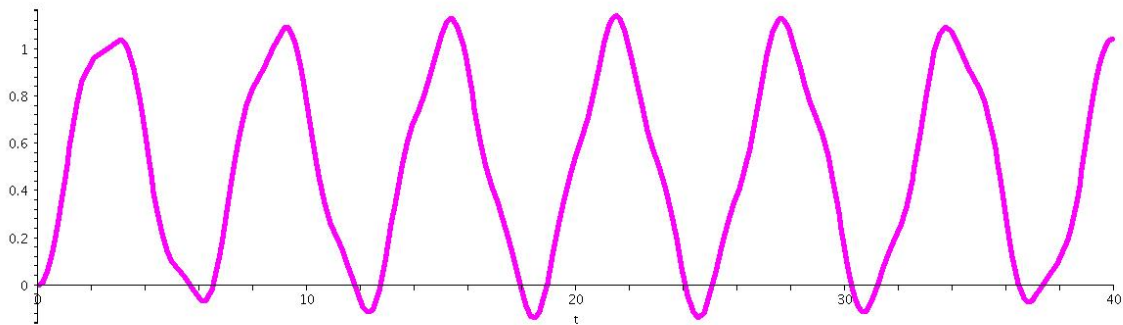

**Student Exercise.** Play! That is experiment with different periods for the square wave and see happens. Do some periods produce a stronger response than others?